

Understanding and Testing the PID Box

What is the PID Box?

The PID box houses the PID controllers (proportional–integral–derivative controller) that monitor RH and flow for the inlet system and apply corrections when the system deviates from the set-points. **Figure 1** shows a traditional front view of the PID box.

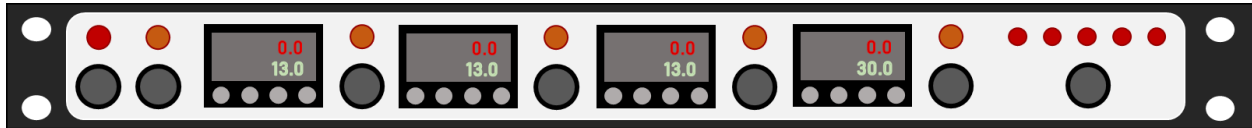

Figure 1: Front view of the PID box. Red and orange circles represent various lights, while grey circles represent the circuit breakers/ power switches.

Walk through of the PID box

On the front of the PID box are all the breakers for power, each PID box has a corresponding breaker on the right side of it and then there are breakers for the raw power (supplies 120 V to the heaters when necessary), power from the UPS, and power for the individual DC power supplies (**Fig. 3**). *When breakers are pulled out then power is not being supplied.* The first three PIDs are for RH measurements and the last one (on the far right) is for flow control. On each PID the red top value is the measured value and the green bottom value is the set point. The set point can be changed using the navigation buttons on the PID (**Fig. 4**), but often these are hard coded in the configuration file under the PID control section and need to be changed there.

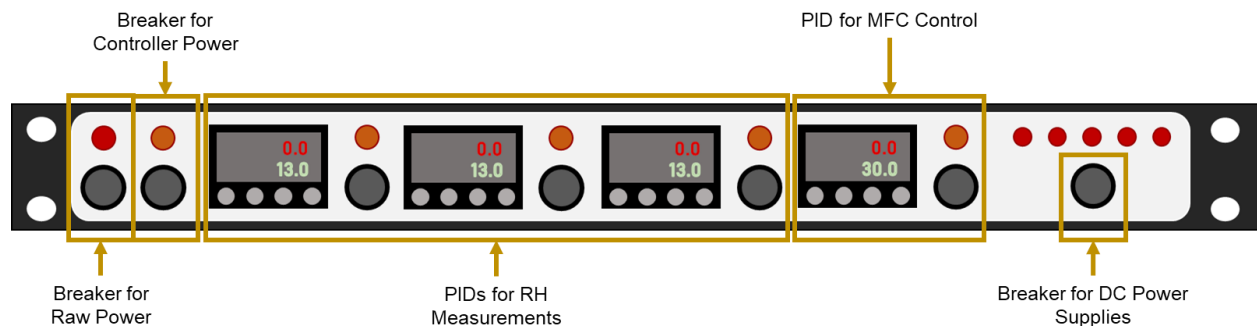

Figure 3: Front walk through of the PID box. Like in Fig. 1 red, orange, and green circles represent various lights, while grey circles represent the circuit breakers.

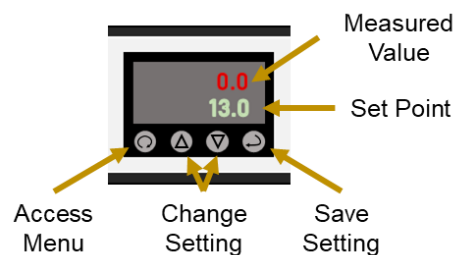

Figure 4: Walk through of the PID screen.

On the back of the PID box there are several important ports which we go through from left to right here (**Fig. 3**). On the left there are 16 possible pressure sensor ports, however, these should be plugged with no actual available connection. Then there is then a 20 pin “analog out” port, which is how the PID is connected to the μ MAC box. There is then a round keyed port for the wire that comes from the impactor box for the mass flow controller (MFC), under this is a three-pin connector that is not used. There are then a set of four pinned connectors, one for each PID. While RH probes can be connected to all four, **only ports 1-3 work for RH sensors** because PID 4 is for the flow control. Next in line is a three-pin connection that is not used, but bellow that the is four pin connection that connects the PID to the serial hub (how we see its data on the laptop). Not that this connection is delicate and is often a point of failure. Following is a set of six, 2-pin connections that are not used. The connections for the heating element for the inlet are next, there are again four (one for each PID) and again **only 1-3 will work and they must be in the port with the correct corresponding RH sensor** (i.e. if your inlet RH is on port 1 then the heater for the inlet must be installed on port 1 in this section). There is another set of unused 2-pin ports before the power ports. There are two, and both must be connected. The first is for general box power, the second is the power supply for the heaters which is only activated when the RH sensors indicate that heating is needed.

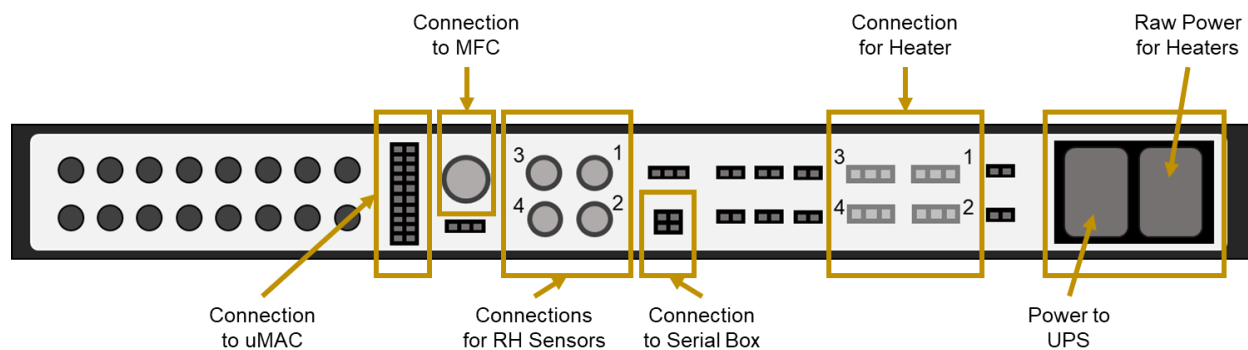

Figure 3: Walk through of the back section of the PID box. Ports that are not used are not labeled in this figure.

Changing the Flow Set Point

A PID controller controls the system flow through a mass flow controller. The system and impactors need 30 liters per minute **volumetric**, however the calibration for the mfc and the set point of the PID is for **standard flow**. Make sure when you are setting the flow for the aerosol sampling that it is the equivalent of 30 vlp_m for the site. Note that the flow needed will be different if you do not have an impactor box.

To do this calculation you need the mass flow controller calibration, as well as an assumed temperature and pressure that approximately correct for the site you are at.

Here is an example of these calculations for Bondville, IL USA (BND) in 2023:

Assume a typical station pressure is 990 mb and typical measurement temperature at the MFC is 294 K. 30 lpm_v is needed at the impactors. Minus the ~ 1 lpm_v that is removed by the CLAP, we need to have ~29 lpm_v.

First, calculate the needed flow in slpm:

$$slpm = vlp_m * \frac{P_{amb}}{P_{std}} * \frac{T_{std}}{T_{amb}} = 29 vlp_m * \frac{990 mb}{1013.25 mb} * \frac{273.15 K}{294 K} = \mathbf{26.3 slpm}$$

Next, use the mass flow controller calibration to get the set point flow (note that these are an example slope and intercept and that you should use the calibration from your site for this):

$$\text{True Flow (slpm)} = (0.8653 * \text{Indicated Flow PID \#4 (slpm)}) + 0.7681$$

$$\text{Indicated Flow PID \#4 (slpm)} = \frac{\text{True Flow (slpm)} - 0.7681}{0.8653} = 29.5 \text{ slpm}$$

Once you get the correct flow set point you can use the methods outlined bellow to change the set point.

Changing the flow using the PID control

- Press the far-left button on the PID control until “SP1” is displayed. This is the menu button shown in **Fig. 2**.

The flow set point will now be the red number above the ‘SP1’ label.

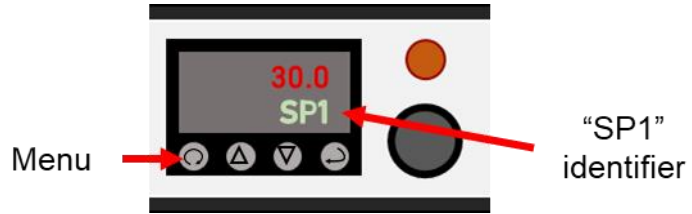

- Press the up and down buttons to increase or decrease the flow set point.
- Press the far-right button on the PID control to save the setting. This is the save setting button shown in **Fig. 2**. The screen will flash once.

Press the menu button on the far-left to return to the measurement screen

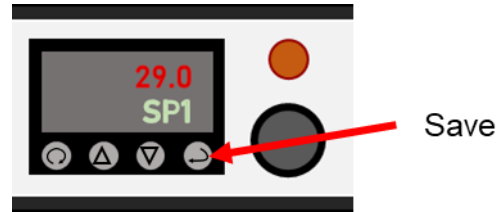

- You should now see the new set point on the bottom in green and the measured flow in red again.

The measured flow should change to be close to the set point.

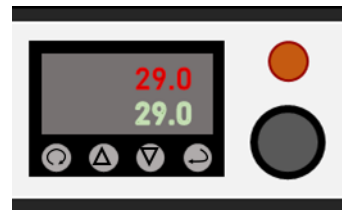

- If the set point does not change when you return to the menu you will need to change the flow set point in the configuration file.

See the next set of instructions to do this.

Changing the flow in the configuration file

- Open the configuration file, and locate the PID lines.

- The flow set point line is early in the PID section and looks like:

```
/aerosol/Components/PID/Controllers/#3/Setpoint,30.0
```

- To change the set point just change the number at the end of this line to the desired flow (the flow set point you calculated):

```
/aerosol/Components/PID/Controllers/#3/Setpoint,29.0
```

- Save and close the configuration file, then close and re-open the acquisition window, then restart acquisition. It may take a couple of system restarts to get the new set point to initiate.

How to test a PID box

Always test your μ MAC box before testing your PID box, as with that test an impactor box will be needed to test the PID box.

Testing the RH sensors and Heating Control

On the laptop navigate to the μ MAC instrument screen in cpd, then change to the next display by pressing “M”, and then “D” Next Display (**Fig. 6**). It is also helpful at this point to recall what the calibration on your μ MAC is for temperature is, but if you have forgotten go back up to the μ MAC testing section and follow those instructions to find your calibration variables.

Attach an RH probe to each channel and a heater to the corresponding 3-pin connector (**Fig. 5**). Then one by one check the following for each port (#1 – 3 because #4 is for flow):

- Check that there is a reasonable RH reading on the PID screen
- Check the temperature readout on the μ MAC screen is reasonable (PID is still useable if this is broken but its good to know which one’s work)
 - o Port 1 will read to Channel 8
 - o Port 2 will read to Channel 9
 - o Port 3 will read to Channel 10
- Breathe on the RH probe and hold it to help maintain high RH, and make sure the heater gets hot (can push-in / pull-out the breaker to quickly modulate power as these heaters get hot fast!)

Testing the MFC Control

You will need flow through the impactor box for this check. Measure flow continuously (setting on the dry cal) at the “Return Flow From Neph” on the impactor box. You don’t need to have a full 30 LPM but it should be reasonably high. In the configuration file lower the flow set point (~10 LPM is a nice spot), save the file, and restart the acquisition system. It may take a few restarts but you should see the setpoint on PID #4 change. If the flow control is working you should see a drop in flow coming from the PIDs attempt to control flow to the set point (the flow may not exactly match if the PID/MFC flow has not been calibrated but you should at least see the drop).